



## ARINC 429 Interface to Gigabit Ethernet

### Features

- Up to 24 ARINC 429 channels per module
- Support for periodic and asynchronous messages
- Advanced scheduling options
- Capture all or selected traffic on fully loaded buses
- Error detection and injection
- File Transfer support
- 16 MB memory for enhanced Data Buffering
- Time-stamping and Timer Synchronisation
- Multi-user Networked Access and Control

### Description

mbs' ÆsyBus product range provides Full Duplex Gigabit Ethernet/IP interfacing to various Avionics and Industrial data buses. ÆsyBus 429 provides this convenient high speed distributed interfacing capability for accessing up to 24 ARINC-429 channels (8 transmit and 16 receive).

A separate document provides more detail on the ÆsyBus concept and how its unique architecture can be exploited to provide a cost effective, distributed interface and processing system with outstanding performance. Many new products are planned to expand this flexible, easy to program family.

### ARINC - 429

ÆsyBus 429 modules are available with: up to 24 channels in various receive/transmit combinations; up to 16 MB of memory for enhanced data buffering; and logic/resources optimised for various Test, File Transfer and General/Airborne applications.

According to need, the user can select between two methods for transmitting ARINC data.

- Dedicated FIFOs which are ideally suited for asynchronous transmissions, needed for file transfer applications, like data loading. Each FIFO buffers up to 2k ARINC 429 words, which are transmitted as soon as an opportunity occurs with a minimum allowable gap between words.



- Transmit Scheduler and Data Buffer, designed for periodic transmissions. This allows up to 128 individually assigned ARINC words to be scheduled on to each of the 8 transmit channels with repetition rates from 10 ms to 4 seconds. Data is drawn from user assigned locations within the Transmit Data Buffer.

Asynchronous and periodic transmissions mix naturally on to the buses with periodic transmissions taking priority.

All ARINC 429 receive channels feature **Error Detection** and optionally independent Label and SDI filtering. Cyclic data buffers are provided for storing receive data for each channel, prior to it being automatically transferred to applications on the host computers together with the appropriate Write Pointers.

Receive data is optionally **Time-Stamped** with a 32-bit counter and a microsecond resolution. The counter can also be read directly and its value transferred to host applications with other data.

It is up to the user to maintain a record of the Cyclic Buffer Read Pointers. The concept of using cyclic buffers rather than FIFOs has a tremendous advantage, in that multiple host applications can read the receive data without it being lost, while FIFOs can only be read once before the data disappears.

### Software

The choice of Ethernet data bus with UDP/IP protocol provides the user with a freedom unimaginable in the past. No longer is it necessary for a single program to control all of the communication. With ÆsyBus 429, the user can divide the system into logical parts and implement them in separate applications: On the same computer or on separate computers attached to the

network, and these connections can be broken and re-connected while the system is working. No need to switch the system down when connecting a new host to the network.

Another advantage of the ÆSyBus 429 is that it requires no special Device Drivers. Almost all serious operating systems and software development environments provide support for Ethernet and the TCP/IP protocol stack, to which UDP belongs. You can take advantage of all the special tools and classes provided by these systems, to easily connect to the (UDP) user ports on the card, or sending and receiving messages etc.

In addition to the support of readily available software development tools, the ÆSyBus 429 comes with example software and support classes written in Visual C# and provided with source code. You don't have to waste time struggling with an unfamiliar programming language and environment. You just continue with your favourite tools, they are almost certain to provide the support you need to access the Ethernet/IP and consequently the ÆSyBus devices. In addition, the ÆSyBus 429 is provided with full documentation and various Windows based utility programs to help you configure IP addresses and check out your network connection.

## Functional Specifications

### General Features

- 10 (optionally 26) UDP user assigned ports
- On board system Timer with support for external synchronisation and clock drift compensation
- 16 MB memory for enhanced Data Buffering
- 100Base-TX / 1000Base-T Ethernet
- UDP/IP message transfer protocol
- Power over Ethernet (PoE) or 12V Power options
- Rugged versions available for Harsh Environments

## ÆSyBus 429 Ordering Information

Part Numbers follow the generic format: <b>Æ-429 - Channel Option - Logic Option - Power Option</b>					
<b>Channel Option:</b>		<b>Logic Option:</b>		<b>Power Option:</b>	
24	8 Transmit 16 Receive	T	Error Insertion and Rx Time Stamping	EC	Euro Card Format: Back-plane 12V Power Input
12	4 Transmit 8 Receive	F	File Transfer Support	EP	Stand-alone Module with External 12V Power Input
06	2 Transmit 4 Receive	G	General Applications	PoE	Stand-alone Module with Power over Ethernet
Example Part Number					
Æ-429-24-F-PoE		8 Transmit 16 Receive, Stand-alone ARINC-429 / Gigabit Ethernet Interface Module with Power over Ethernet and support for File Transfer.			

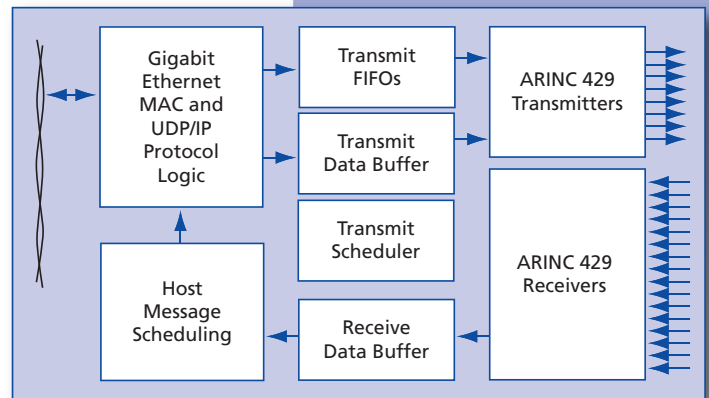

**Another advantage of the ÆSyBus 429 is that it requires no special Device Drivers. Almost all serious operating**

### Transmit Features

- Up to 8 Transmit Channels
- Transmit speed select 12.5 k or 100 k bits/s
- Transmit Error insertion and multiple non-standard speed select (optional)
- Support for ARINC File Transfer (optional)
- Transmit FIFOs up to 2k words deep for asynchronous transmission
- Transmit Scheduling for 128 words per channel with periods selectable between 10 ms and 4 seconds

### Receive Features

- Up to 16 Receive channels
- Receive Error reporting
- Receive Filter on Label / SDI and Channel (optional)
- Time Stamping of all Receive Arinc-429 words to 1 microsecond resolution (optional)
- Cyclic buffers for receive data and Time Stamps
- Support for ARINC File Transfer (optional)
- User configurable data transfer scheduling to host applications, periodically and/or when necessary.